



UNIVERSAL light

Technical Brochure

Patch Fittings for
Toughened Glass
Assemblies

dormakaba 

UNIVERSAL light – Patch fittings and floor springs for toughened glass doors

dormakaba offers an array of superb solutions suitable for the installation of almost any conventional type of standard toughened glass door. One such hardware line is the UNIVERSAL light range with various options to meet the requirements of different fixing situations.

The glass preparations that are needed can be performed quickly and easily.

Quality materials and thorough workmanship guarantee a long service life and a reflection of excellence for years to come.

The door fittings are designed for leaf weights up to 100 kg (leaf widths up to max. 1,100 mm). Available with high-quality covers of stainless steel – with the choice of satinised or polished. Suitable for glass thicknesses of 10 and 12 mm. All fittings subjected to 200,000 operating cycles in tests aligned to EN 1154.

UNIVERSAL light Patch Fittings

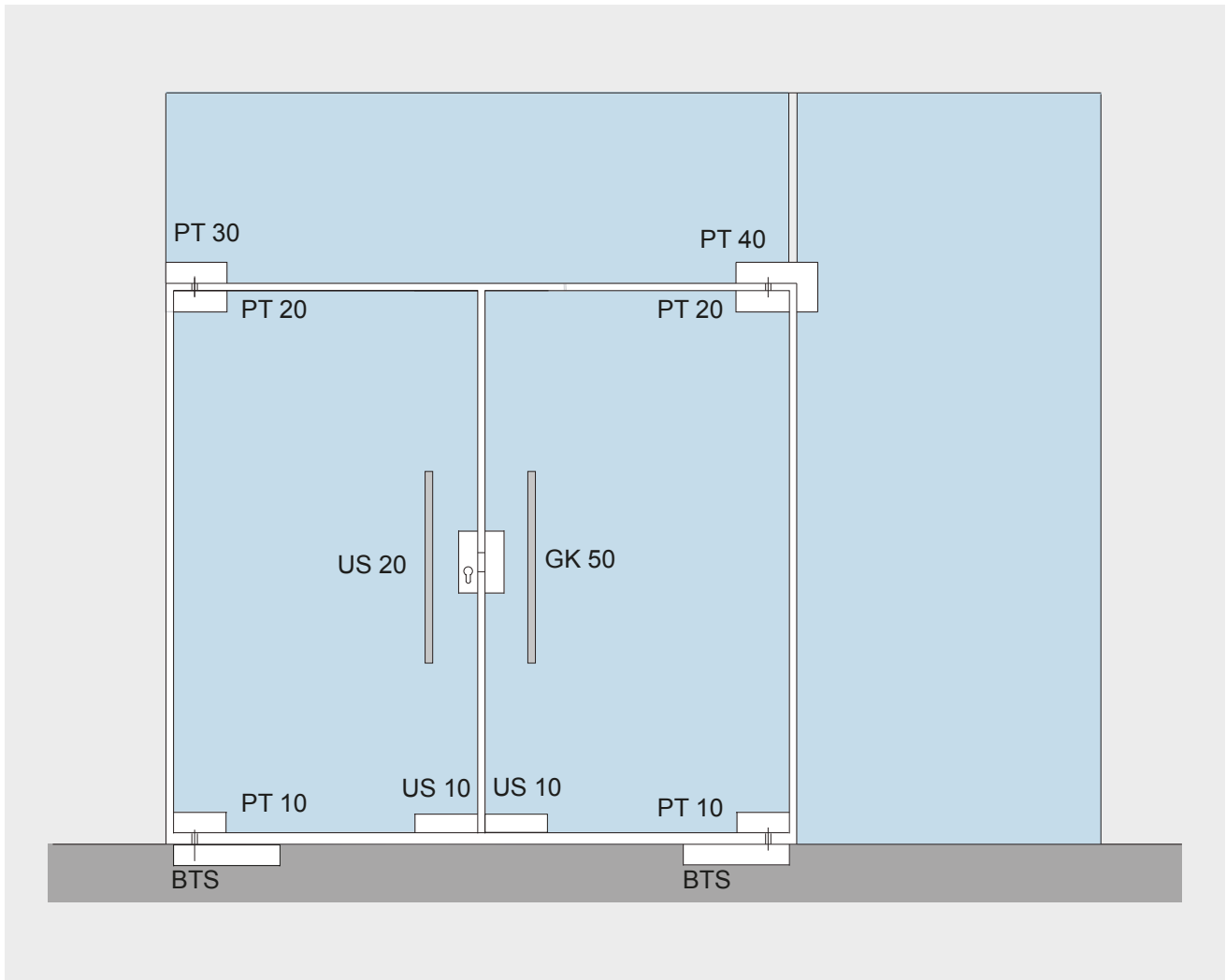

PT	= Patch fittings (clamped)
US	= Locks
GK	= Strike box
BTS	= Floor spring
PSS	= Polished Stainless Steel
SSS	= Satin Stainless Steel

Maximum door weight and width for UNIVERSAL light patch fittings

max. door weight: 100 kg
max. door width: 1,100 mm

For door weights up to 150 kg and widths up to 1,400 mm, TP/TA door rails should be used.

Glass thickness:

UNIVERSAL light patch fittings are suitable for 10 mm and 12 mm glass.

Patch fittings

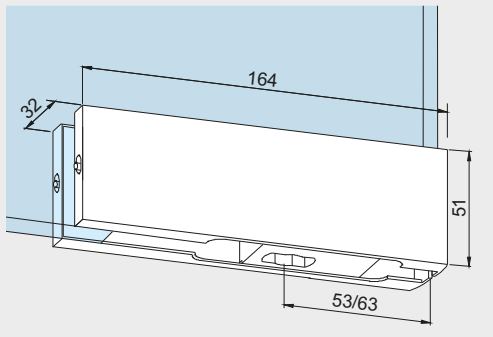
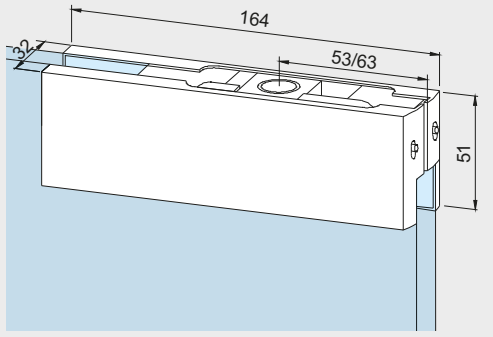
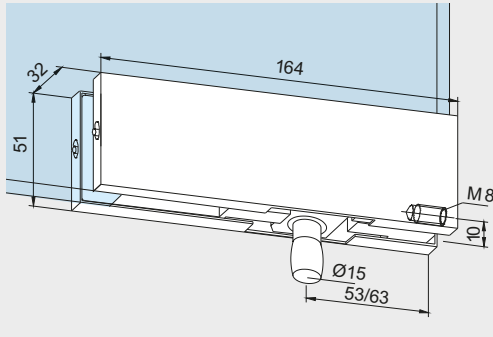
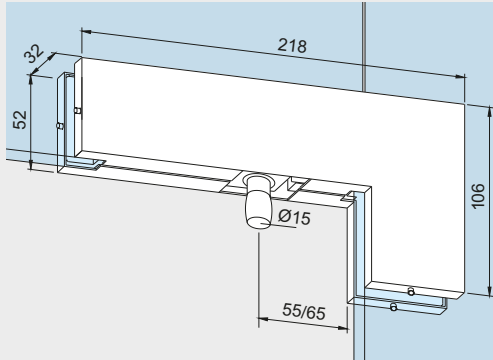
	Product description	Art. No.
	<p>PT 10 UNIVERSAL light bottom patch with insert for dormakaba floor spring or round pivot</p> <p>Weight: 0.580 kg</p>	<p>03.502</p>
	<p>PT 20 UNIVERSAL light top patch with insert for top pivot</p> <p>Weight: 0.566 kg</p>	<p>03.512</p>
	<p>PT 30 UNIVERSAL light overpanel patch with pivot</p> <p>Weight: 0.616 kg</p>	<p>03.522</p>
	<p>PT 40 UNIVERSAL light overpanel/sidepanel patch with pivot</p> <p>Weight: 1.036 kg</p>	<p>03.542</p>

Patch fittings

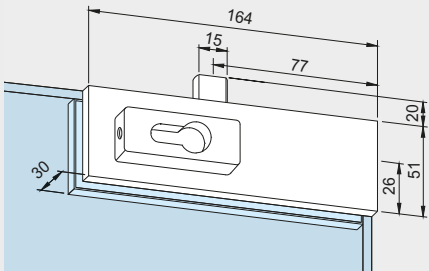
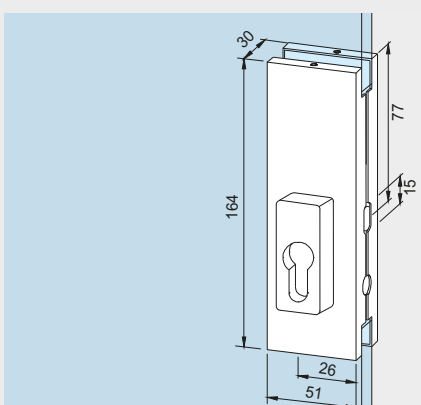
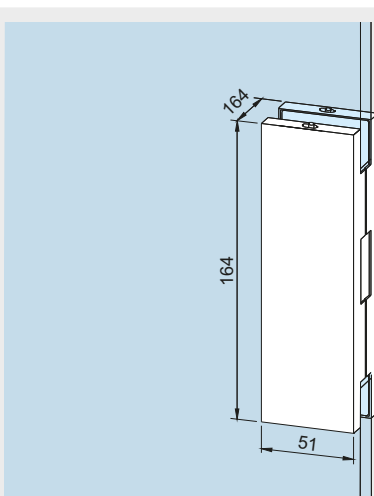
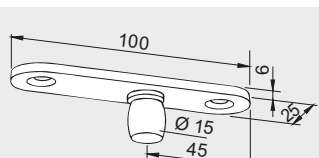
	Product description	Art. No.
	<p>US 10 UNIVERSAL light corner lock with Europrofile cylinder, single throw, bolt projection 15 mm, with security rosettes on both sides</p> <p>Weight: 0.798 kg</p>	<p>03.608</p>
	<p>US 20 UNIVERSAL light centre lock with Europrofile cylinder, single throw, bolt projection 15 mm, with security rosettes on both sides.</p> <p>Weight: 0.738 kg</p>	<p>03.617</p>
	<p>GK 50 UNIVERSAL light strike box prepared for keeping US 20 bolt.</p> <p>Weight: 0.408 kg</p>	<p>03.526</p>
	<p>PT 24 UNIVERSAL light top pivot</p> <p>Weight: 0.107 kg</p>	<p>03.623</p>

Glass Preparation

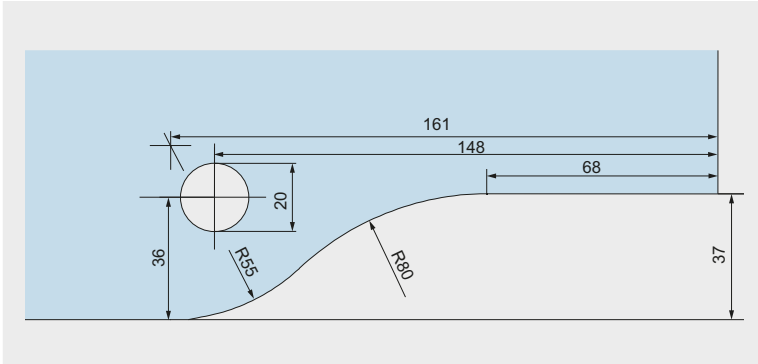

PT 10 / 20 / 30 UNIVERSAL light

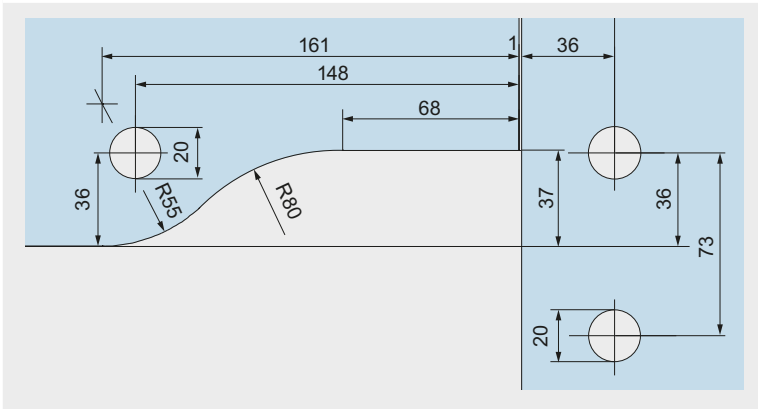

PT 40 UNIVERSAL light

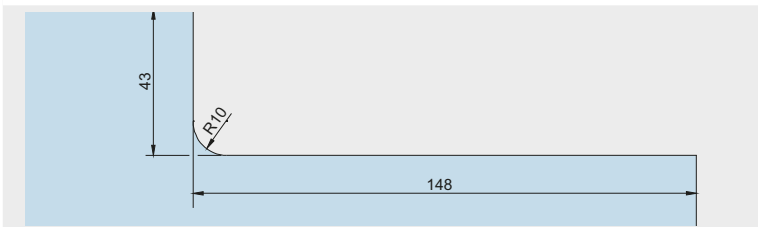

US 10 UNIVERSAL light

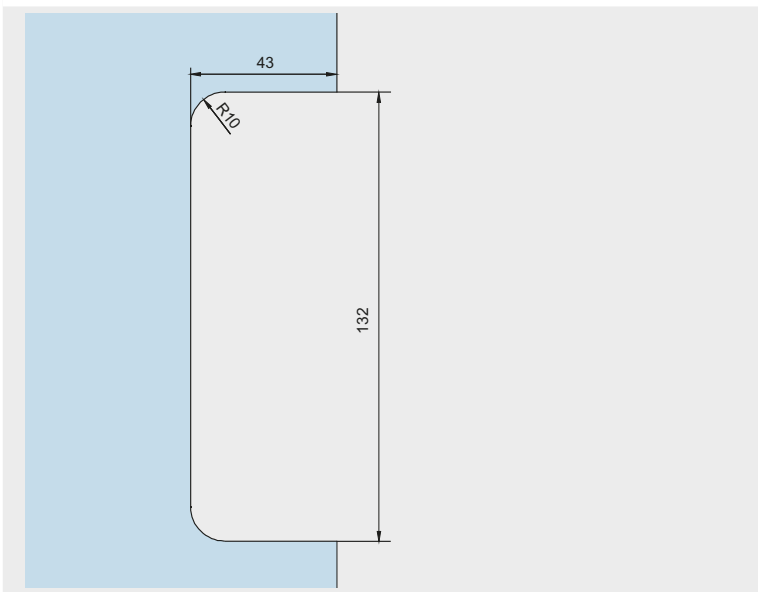

US 20 / GK 50

Space for your notes



Door Hardware



Entrance systems



**Electronic
Access & Data**



**Interior
Glass Systems**



**Mechanical
Key Systems**



Service

dormakaba UK & Ireland

E: info.gb@dormakaba.com

Wilbury Way, Hitchin
Hertfordshire
SG4 0AB

T: +44(0)1462 477600
F: +44(0)1462 477601

Lower Moor Way
Tiverton, Devon
EX16 6SS

T: +44(0)870 000 5625
F: +44(0)870 000 5397